



flightDAQ2-32/64

32/64 Channel Advanced Pressure Scanner

- New and advanced use of digital sensor technology.
- New compact design
- Unparalleled Data Quality: up to 0.02% of full scale
- High speed : 400Hz per channel
- Absolute and differential measurements
- Electrically driven valve for purge and re-zero
- Complete with IEEE 1588 PTPv2 time stamping
- Internal Heaters for use down to -55°C
- 24 bit ADC per channel
- Output over Ethernet (100Mbit TCP/IP / UDP), Chell native protocol, CAN and IENA
- Quick disconnect measurement couplings
- Fully configurable over Ethernet with embedded web server

The Chell flightDAQ2 is another step forward in Chell's long line of pressure scanners optimised for test cell and flight use. The flightDAQ2 makes use of high accuracy digital absolute transducers to give unparalleled performance in the most compact package - even in the most demanding environments.

The flightDAQ2 will output differential or absolute temperature compensated engineering unit pressure data over Ethernet with the Chell native protocol, IENA, and CAN at speeds up to 400Hz per channel. For ease of setup, this can be accomplished over the Ethernet interface or with the intuitive in-built web server.

The flightDAQ2 incorporates an electrically driven shuttle valve for purge and re-zero - therefore removing the need for high pressure supply lines associated with previous versions. The shuttle valve features positional feedback, current sensing on the motor and a count of the number of shuttles to help with planning maintenance requirements. The valve life is tested to 10,000 cycles.

For cold applications, it has an in-built heater to maintain valve operation at cold temperatures.. In addition, there is an internal purge control valve to switch the purge gas on and to vent it before the valve is returned to run.

External measurement connectors are made with the Chell MD3 quick disconnect top plate allowing a quick change of testing scenarios.

The flightDAQ2 is designed for on-engine as well as airframe applications and as such is tested to D0160G.

General	
Differential ranges available	1, 2.5, 5, 7, 10,17, 35, 55, 103, 207 and 310, 689, 1034 kPa
Number of channels	32
Maximum acquisition speed (measurements / channel / second)	400 (200 for ranges \geq 689 kPa)
Data Output	
Output types	Ethernet (TCP/IP & UDP), IENA and CAN
Ethernet Specification	100Mbit TCP/IP or UDP (user configurable)
Performance	
System Accuracy	See table below
Absolute Ranges	160 kPa, 400 kPa and 1140 kPa
Calibrated absolute pressure range for differential range \leq 55 kPa (8 psid)	13 kPa to 160 kPa (1.89 psia to 23.2 psia)
Calibrated absolute pressure range for differential ranges between 103 kPa (15 psi) and 300 kPa (43.5 psid)	13 kPa to 400 kPa (1.89 psia to 58 psia)
Calibrated absolute pressure range for differential range \geq 689 kPa (100 psid))	13 kPa to 1140 kPa (1.89 psia to 165 psia)
Line pressure effect	Negligible
Proof Pressure	Ranges \leq 55 kPa : 35 kPa (50 psig), Ranges $>$ 55 kPa : 1380 kPa (200 psig)
Output Resolution	16 bit or \pm range / 65536
System Resolution	24 bit
Mechanical	
Dimensions (width x depth x height in mm)	180 x 87 x 60 excluding mating QDC
Weight (Valved / non-valved)	600g (est)
Enclosure Sealing	IP54
Measurement ports	1.0mm bulged tubulations
Purge port	2.3 mm (0.09") bulged tubulation
Purge, cal and reference ports	5/16"-24 SAE O ring boss
Maximum purge pressure	10 bar gauge
Purge Flow	11 SLPM at 1 bar purge, 46 SLPM at 2 bar purge and 66 SLPM at 3 bar purge
Power Supply	
DC Power	18 to 32 VDC with smart sensing power supply max current = 1.25A at 28VDC
Electrical Connector	TV06ZN-11-35PN-UWBSB2
Environment	
Operating Temperature Range	-55 to +90°C
Compensated Temperature Range	-55 to +90°C with heaters enabled
Storage Temperature Range	-55 to +90°C
Ambient Pressure	5 mbar abs to 2.5 bar abs
Vibration	Engine standard vibration test to DO160E category S, curve W with duration of 1 hr/axis. Fan blade (20 g 2 kHz)
Shock	Fan blade out to DO160F section 7 (40g 11 m/s)
Maximum relative humidity	95% at 50°C (non-condensing)
Radiated emissions	MIL standard 461-E: RE102
Conducted emissions	MIL standard 461-E/MIL standard 461-C
Timing / Data Synchronisation	
Time Stamping	IEEE 1588 PTPv2
Time Stamping Resolution	1 μ s
Hardware Trigger	5 V TTL pulse, maximum 400 Hz, minimum 2 Hz

flightDAQ2 Accuracy - A Metrology Approach

The performance and flexibility of the flightDAQ2 calls for a different approach to specifying its accuracy. The table below details the resolution, standard deviation and errors with 95% confidence (2 x sigma). This is comparable with data from other manufacturers.

In addition to this, we have detailed the measurement uncertainty which takes into account the following sources of error:

- Uncertainty of the Chell calibration standards used in production
- Thermal errors from 0 to 90°C
- Drift errors over 12 months

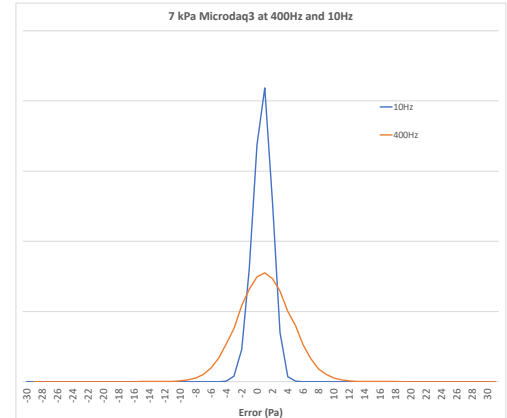

Differential Range (+/-) ¹	Output Resolution (Pa)	Standard Deviation (Pa) ³	Error (95% Confidence)		Uncertainty
			±Pa	%FS ²	%FS ²
1 kPa	4" water	0.03	0.91	1.82	0.2% 0.4%
2.5 kPa	10" water	0.08	0.91	1.82	0.07% 0.15%
5 kPa	20" water	0.15	0.91	1.82	0.04% 0.08%
7 kPa	1 psi	0.21	1.1	2.26	0.03% 0.06%
10 kPa	1.5 psi	0.31	1.25	2.5	0.03% 0.04%
17 kPa	2.5 psi	0.52	1.5	3.0	0.02% 0.03%
35 kPa	5 psi	1	2.01	7.0	0.02% 0.03%
55 kPa	8 psi	1.7	1.71	11	0.02% 0.03%
-83 kPa to 103 kPa	-12 to 15 psi	3.15	3.0	20	0.02% 0.03%
-83 kPa to 207 kPa	-12 to 30 psi	6.3	5	40	0.02% 0.03%
-83 kPa to 300k Pa	-12 to 43.5 psi	9.5	9.0	60	0.02% 0.03%
-83 kPa to 689 kPa ⁴	-12 to 100 psi	21	100	300	0.04% 0.05%
-83 kPa to 1034 kPa ⁴	-12 to 150 psi	30	150	400	0.04% 0.05%

1) Differential range assumes a reference of 1 bar. Reference pressure can vary as long as all measurements are within the absolute range of the transducers.
 2) %FS values refer to the percentage of the differential range as listed.

3) Data collected in accuracy mode with an average of 16.
 4) Provisional

Absolute Range	Output Resolution (Pa)	Standard Deviation (Pa) ¹	Error (95% Confidence)		Uncertainty
			±Pa	%FS ²	%FS ²
Absolute range for differential ranges up to 35 kPa (5 psi)					
15 ³ to 115 kPa	2.2 psia to 16.8 psia	1.5	1.13	20	0.02% 0.025%
Absolute range for differential range of 55 kPa (8 psi)					
13.0 ³ to 160 kPa	1.885 psia to 23.2 psia	2.24	1.6	30	0.02% 0.025%
Absolute range for differential range of 103 kPa (15 psi)					
15.0 ⁴ to 206 kPa	2.2 psia to 29.9 psia	2.9	3.5	40	0.02% 0.025%
Absolute range for differential range of 207 and 300 kPa (30 and 43.5 psi)					
0 ⁴ to 400 kPa	0 psia to 58.01 psia	6.1	6	60	0.02% 0.025%
Absolute range for differential range of 689 and 1034 kPa (100 and 150 psi)					
0 ⁶ to 1140 kPa ⁷	0 psia to 165 psia	17	400	1000	0.08% 0.1%

1) Data collected in accuracy mode with an average of 16
 2) %FS values refer to the percentage of the maximum absolute values as listed.
 3) Lowest measurable absolute pressure for ranges up to 160kPa is 11kPa.
 4) Lowest measurable absolute pressure for 206 and 400 kPa range ranges is 0.5kPa.

5) Lowest absolute calibrated pressure is 14 kPa as standard (please contact us for lower pressures)
 6) Lowest measurable absolute pressure for 1140kPa range is 11kPa.
 7) Provisional

Digital Transducers - A revolution in data quality

The digital transducers used in the flightDAQ2 provide unparalleled data quality. When the pressure and temperature output for each transducer are processed with our proprietary thermal compensation routine, the results set a new standard for pressure scanners and a considerable improvement over the older flightDAQ2 product range.

The histogram opposite shows a 15 psid flightDAQ2 when compared to the data from an older flightDAQ2 which incorporate a digitally thermally compensated scanner using conventional transducers.

This performance removes the need for on-line calibration and, in most cases, rezero.

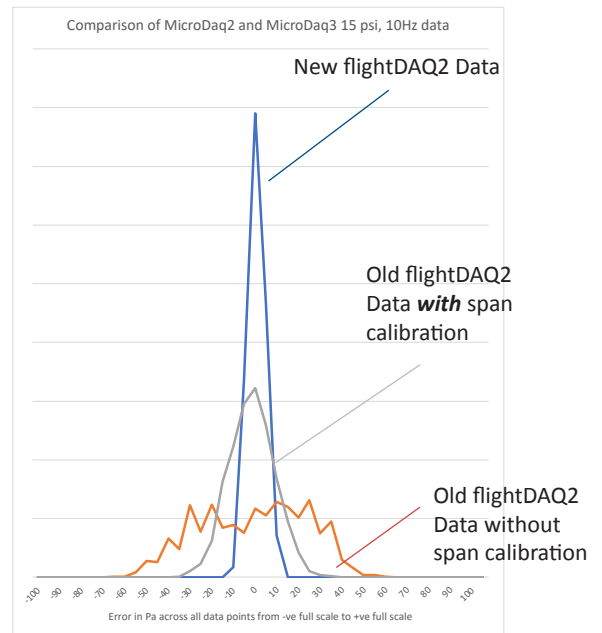

FlightDaq2 Pneumatic Layout - Run Mode

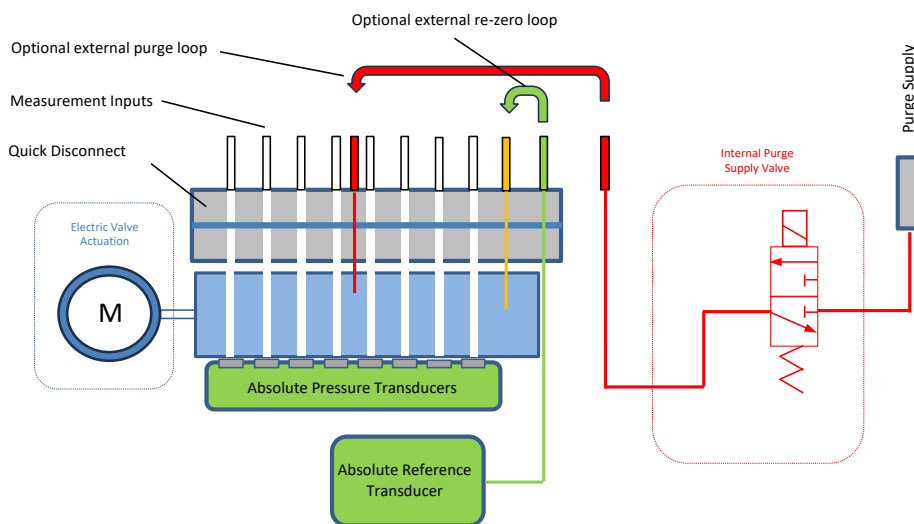

FlightDaq2 Pneumatic Layout - Purge Mode

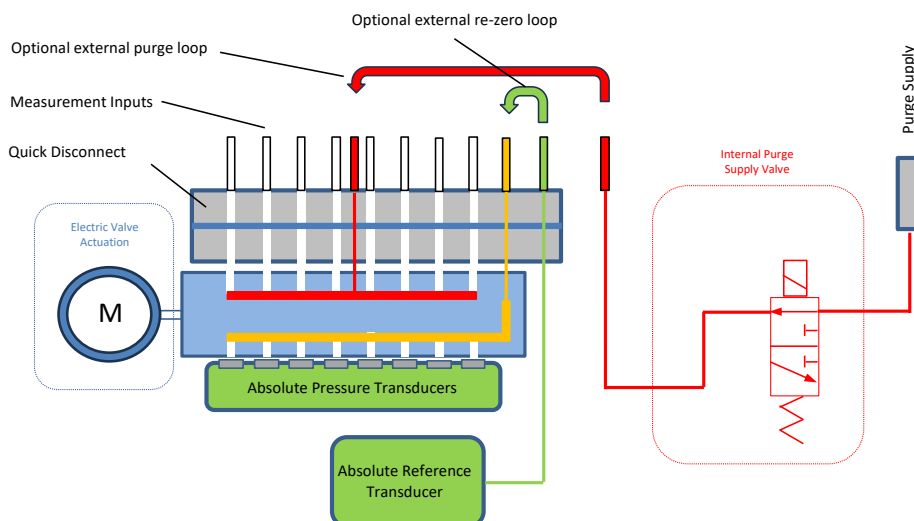

flightDAQ2 Dimensions

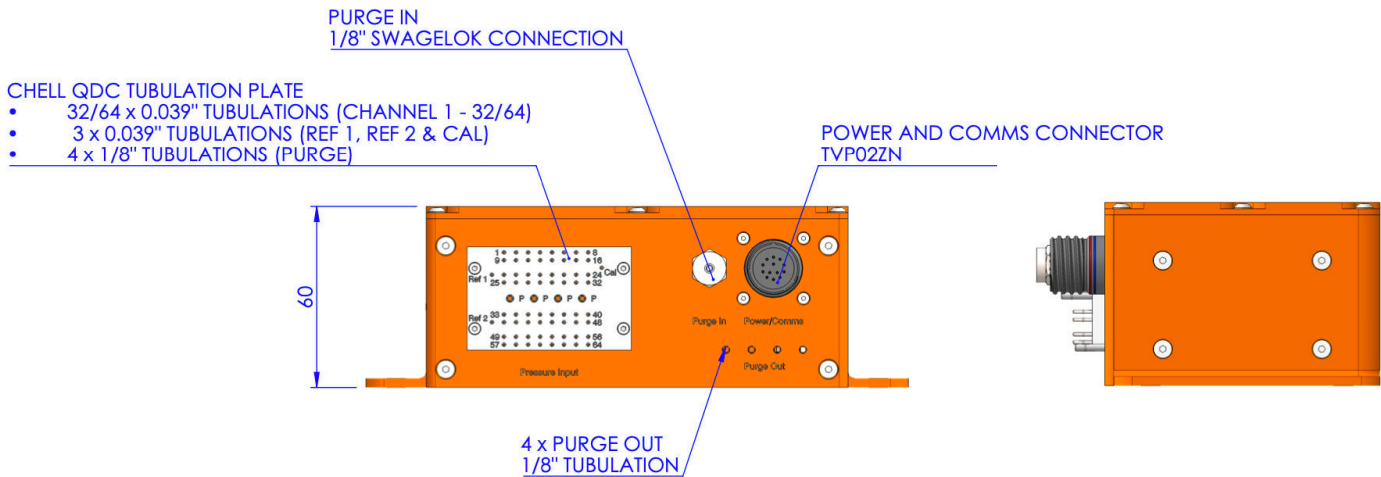
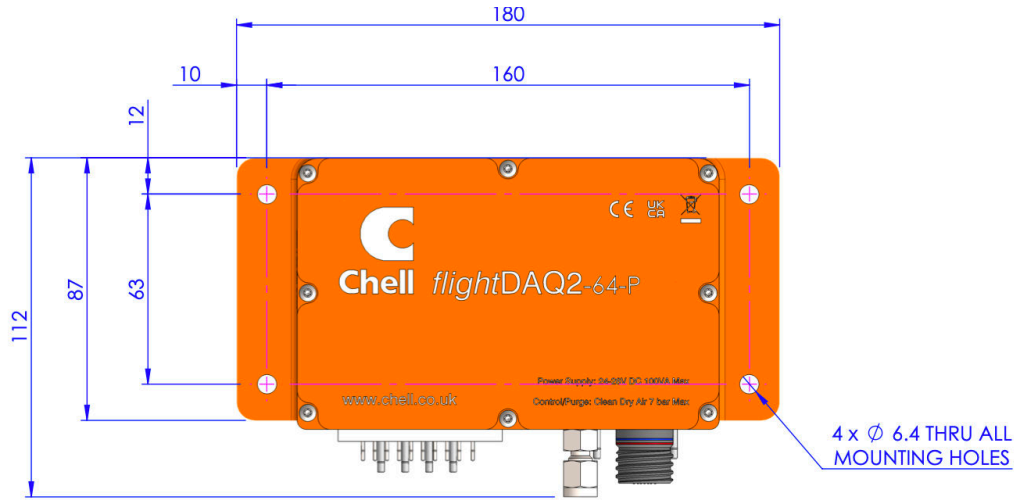

Part Number:

32FD2-AABBCCDD - 32 channel version

64FD2-AABBCCDD - 64 channel version

AA = Range

- 01 = 1 kPa (4" water)
- 02 = 2.5 kPa (10" water)
- 03 = 5 kPa (20" water)
- 04 = 7 kPa (1 psi)
- 05 = 10 kPa (1.5 psi)
- 06 = 17 kPa (2.5 psi)
- 07 = 35 kPa (5 psi)
- 08 = 55 kPa (8 psi)
- 09 = 103 kPa (15 psi)
- 10 = 207 kPa (30 psi)
- 11 = 310 kPa (45 psi)
- 12 = 689 Kpa (100 psi)
- 13 = 1034 Kpa (150 psi)

BB = Measurement ports

- 00 = supplied with mating QDC plate (1.0mm (0.040") bulged tubulations)

DD = Purge ports

- 01 = 5/16" - SAE O-ring boss
- 02 = 1/8" Swagelok®
- 03 = AS205 quick disconnect

CC = Interface / Supply

- 01 = TV06ZN-11-35PN-UWBSB2