



Chell - 2432

32 Channel Advanced Pressure Scanner

- New and advanced use of digital sensor technology.
- Optional iDDS interface
- Unparalleled Data Quality: up to 0.02% of full scale
- High speed : 200Hz per channel
- Absolute and differential measurements
- Electrically driven valve for purge and re-zero
- Power-over-Ethernet
- Complete with IEEE 1588 PTPv2 time stamping
- 24 bit ADC per channel
- Output over Ethernet (100Mbit TCP/IP / UDP), Chell native protocol, Netscanner protocol, iDDS and IENA
- Quick disconnect measurement couplings
- Fully configurable over Ethernet with embedded web server

The Chell 2432 is another step forward in Chell's long line of pressure scanners optimised for test cell use. The 2432 makes use of high accuracy digital absolute transducers to give unparalleled performance - even in the most demanding environments.

The Chell 2432 will output differential or absolute temperature compensated engineering unit pressure data over Ethernet with the Chell native protocol, IENA, and iDDS at speeds up to 200Hz per channel. It also features a Netscanner emulation mode where a subset of the Netscanner commands are supported to facilitate their use in existing installations.

The Chell 2432 incorporates an electrically driven shuttle valve for purge and re-zero - therefore removing the need for high pressure supply lines associated with previous versions. The shuttle valve features positional feedback, current sensing on the motor and a count of the number of shuttles to help with planning maintenance requirements. The valve life is tested to 10,000 cycles.

External measurement connectors are made with the Chell SQDC range which are durable, high temperature quick disconnects. These are compatible with both flexible and solid tubes. The calibration, reference and purge connections are via 5/16-24 SAE 'O' ring boss which can be fitted with double ferrule compression fittings or Chell AS series quick disconnects.

The Chell 2432 incorporates an internal purge control valve to switch the purge gas on and to vent it before the valve is returned to run.

The 2432 has a smart power supply which is compatible with a DC supply and PoE. The 2432 will always use a DC supply if it senses one - otherwise it will negotiate with a PoE enabled switch for power.

With the addition of an iDDS run time license, the 2432 is fully compatible with iDDS installations.

General	
Differential ranges available	1, 2.5, 5, 7, 10,17, 35, 55, 103, 207 and 310, 689, 1034 kPa
Number of channels	32
Maximum acquisition speed (measurements / channel / second)	200
Data Output	
Output types	Ethernet (TCP/IP & UDP), Chell and Netscanner protocols, IENA and iDDS (optional)
Ethernet Specification	100Mbit TCP/IP or UDP (user configurable)
Performance	
System Accuracy	See table below
Absolute Ranges	See table below
Calibrated absolute pressure range for differential range \leq 55 kPa (8 psid)	13 kPa to 160 kPa (1.89 psia to 23.2 psia)
Calibrated absolute pressure range for differential ranges between 103 kPa (15 psi) and 300 kPa (43.5 psid)	13 kPa to 400 kPa (1.89 psia to 58 psia)
Calibrated absolute pressure range for differential range \geq 689 kPa (100 psid))	13 kPa to 1140 kPa (1.89 psia to 165 psia)
Line pressure effect	Negligible
Proof Pressure	Ranges \leq 55 kPa : 350 kPa (50 psig), Ranges $>$ 55 kPa : 1380 kPa (200 psig)
Output Resolution	16 bit or \pm range / 65536
System Resolution	24 bit
Mechanical	
Dimensions (width x depth x height in mm)	241 x 89 x 115 excluding mating SQDC
Weight (Valved / non-valved)	2 kg
Enclosure Sealing	IP54
Measurement ports	1.0mm or 1.6mm bulged tubulations, 1mm or 1/16" solid tubing - all via mating SQDC
Purge, cal and reference ports	5/16"-24 SAE O ring boss fitted with 1/8" compression fittings
Maximum purge pressure	7 bar gauge
Purge Flow	22 SLPM at 1 bar purge, 46 SLPM at 2 bar purge and 66 SLPM at 3 bar
Power Supply	
DC Power	18 to 32 VDC with smart sensing power supply max current = 1.0A at 28VDC
PoE Specification	IEEE 802.3at (Type 1 and 2)
Electrical Connector	09-49-15KPT06FS
Environment	
Operating Temperature Range	0 to +90°C
Compensated Temperature Range	0 to +90°C with option for -20 to 90°C
Storage Temperature Range	-55 to +90°C
Ambient Pressure	100 mbar abs (52,000 ft) to 2.5 bar abs
Vibration	Engine standard vibration test to DO160E category S, curve W with duration of 1 hr/axis. Fan blade (20 g 2 kHz)
Shock	Fan blade out to DO160F section 7 (40g 11 m/s)
Maximum relative humidity	95% at 50°C (non-condensing)
Radiated emissions	MIL standard 461-E: RE102
Conducted emissions	MIL standard 461-E/MIL standard 461-C
Timing / Data Synchronisation	
Time Stamping	IEEE 1588 PTPv2
Time Stamping Resolution	1 μ s
Hardware Trigger	5 V TTL pulse, maximum 400 Hz, minimum 2 Hz

2432 Accuracy - A Metrology Approach

The performance and flexibility of the Chell 2432 calls for a different approach to specifying its accuracy. The table below details the resolution, standard deviation and errors with 95% confidence (2 x sigma). This is comparable with data from other manufacturers.

In addition to this, we have detailed the measurement uncertainty which takes into account the following sources of error:

- Uncertainty of the Chell calibration standards used in production
- Thermal errors from 0 to 90°C
- Drift errors over 12 months

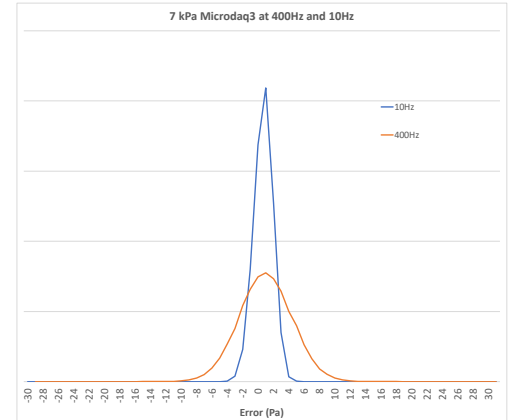

Differential Range (+/-) ¹	Output Resolution (Pa)	Standard Deviation (Pa) ³	Error (95% Confidence)		Uncertainty	
			±Pa	%FS ²	%FS ²	
1 kPa	4" water	0.03	0.91	1.82	0.2%	0.4%
2.5 kPa	10" water	0.08	0.91	1.82	0.07%	0.15%
5 kPa	20" water	0.15	0.91	1.82	0.04%	0.08%
7 kPa	1 psi	0.21	1.1	2.26	0.03%	0.06%
10 kPa	1.5 psi	0.31	1.25	2.5	0.03%	0.04%
17 kPa	2.5 psi	0.52	1.5	3.0	0.02%	0.03%
35 kPa	5 psi	1	2.01	7.0	0.02%	0.03%
55 kPa	8 psi	1.7	1.71	11	0.02%	0.03%
-83 kPa to 103 kPa	-12 to 15 psi	3.15	3.0	20	0.02%	0.03%
-83 kPa to 207 kPa	-12 to 30 psi	6.3	5	40	0.02%	0.03%
-83 kPa to 300k Pa	-12 to 43.5 psi	9.5	9.0	60	0.02%	0.03%
-83 kPa to 689 kPa ⁴	-12 to 100 psi	21	100	300	0.04%	0.05%
-83 kPa to 1034 kPa ⁴	-12 to 150 psi	30	150	400	0.04%	0.05%

1) Differential range assumes a reference of 1 bar. Reference pressure can vary as long as all measurements are within the absolute range of the transducers.

2) %FS values refer to the percentage of the differential range as listed.

3) Data collected at 100Hz with an average of 16.

4) Provisional

Absolute Range	Output Resolution (Pa)	Standard Deviation (Pa) ¹	Error (95% Confidence)		Uncertainty	
			±Pa	%FS ²	%FS ²	
Absolute range for differential ranges up to 35 kPa (5 psi)						
15 ³ to 115 kPa	2.2 psia to 16.8 psia	1.5	1.13	20	0.02%	0.025%
Absolute range for differential range of 55 kPa (8 psi)						
13.0 ³ to 160 kPa	1.885 psia to 23.2 psia	2.24	1.6	30	0.02%	0.025%
Absolute range for differential range of 103 kPa (15 psi)						
15.0 ⁴ to 206 kPa	2.2 psia to 29.9 psia	2.9	3.5	40	0.02%	0.025%
Absolute range for differential range of 207 and 300 kPa (30 and 43.5 psi)						
0 ⁴ to 400 kPa	0 psia to 58.01 psia	6.1	6	60	0.02%	0.025%
Absolute range for differential range of 689 and 1034 kPa (100 and 150 psi)						
0 ⁶ to 1140 kPa ⁷	0 psia to 165 psia	17	400	1000	0.08%	0.1%

1) Data collected at 100Hz with an average of 16

2) %FS values refer to the percentage of the maximum absolute values as listed.

3) Lowest measurable absolute pressure for ranges up to 160kPa is 11kPa.

4) Lowest measurable absolute pressure for 206 and 400 kPa range ranges is 0.5kPa.

5) Lowest absolute calibrated pressure is 14 kPa as standard (please contact us for lower pressures)

6) Lowest measurable absolute pressure for 1140kPa range is 11kPa.

7) Provisional

Digital Transducers - A revolution in data quality

The digital transducers used in the flightDAQ3 provide unparalleled data quality. When the pressure and temperature output for each transducer are processed with our proprietary thermal compensation routine, the results set a new standard for pressure scanners and a considerable improvement over the earlier flightDAQ2 product range.

The histogram opposite shows a 15 psid 2432 when compared to the data from a flightDAQ2 which incorporate a digitally thermally compensated scanner using conventional transducers.

This performance removes the need for on-line calibration and, in most cases, rezero.

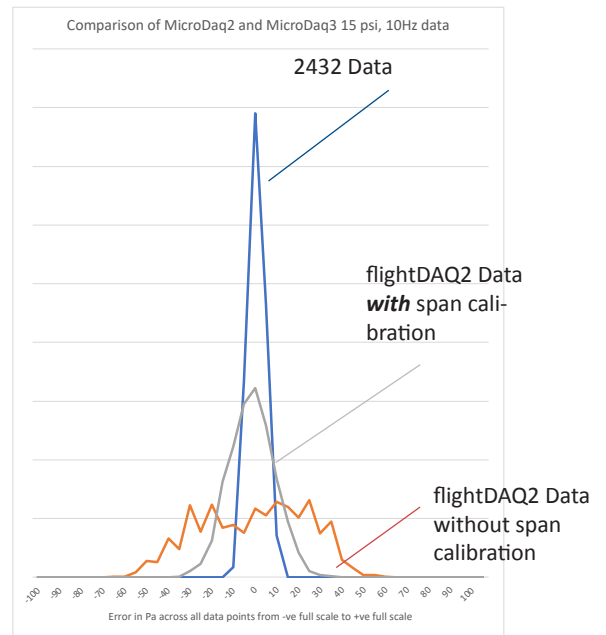

2432 Pneumatic Layout - Run Mode

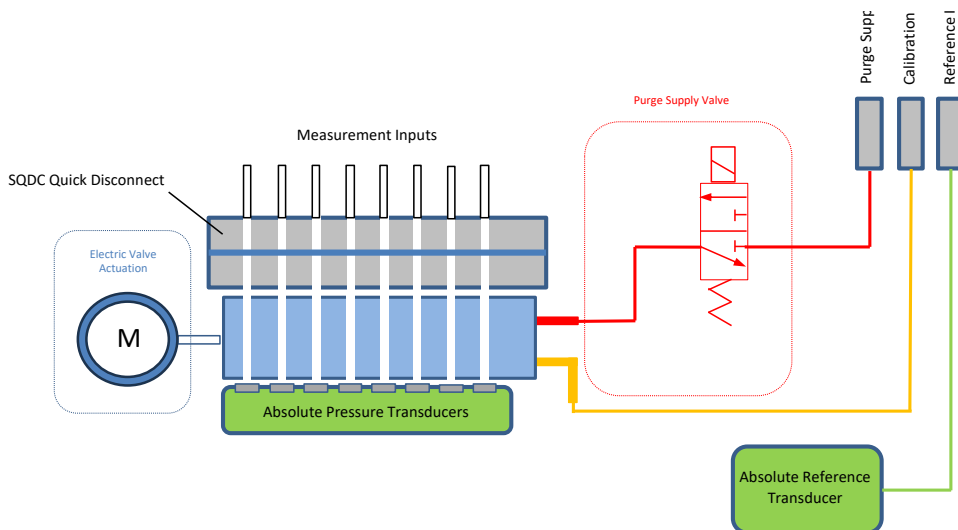

2432 Pneumatic Layout - Purge Mode

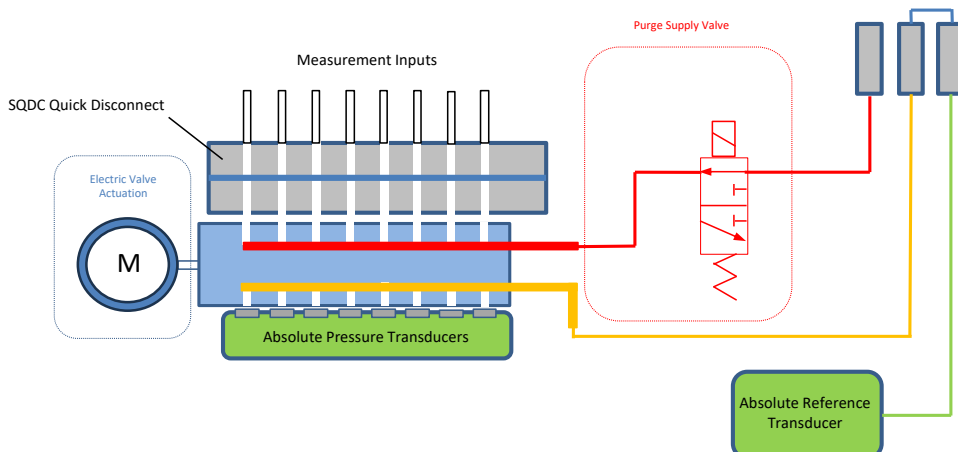

2432 Dimensions

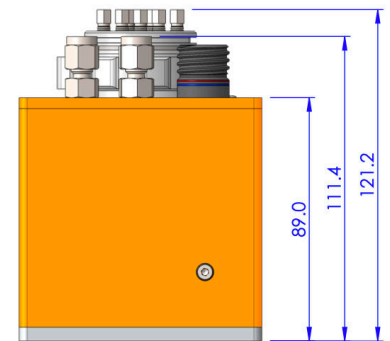
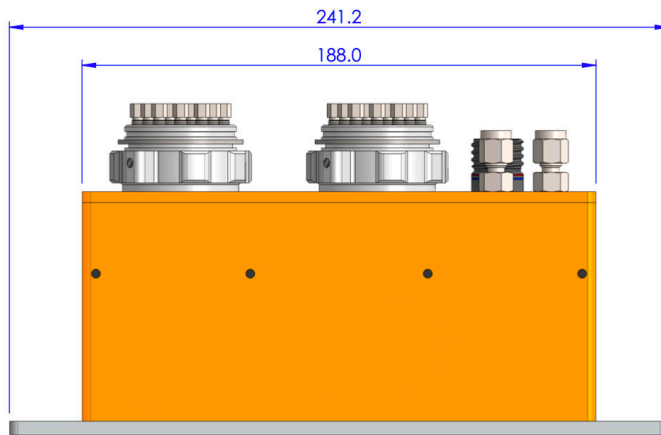
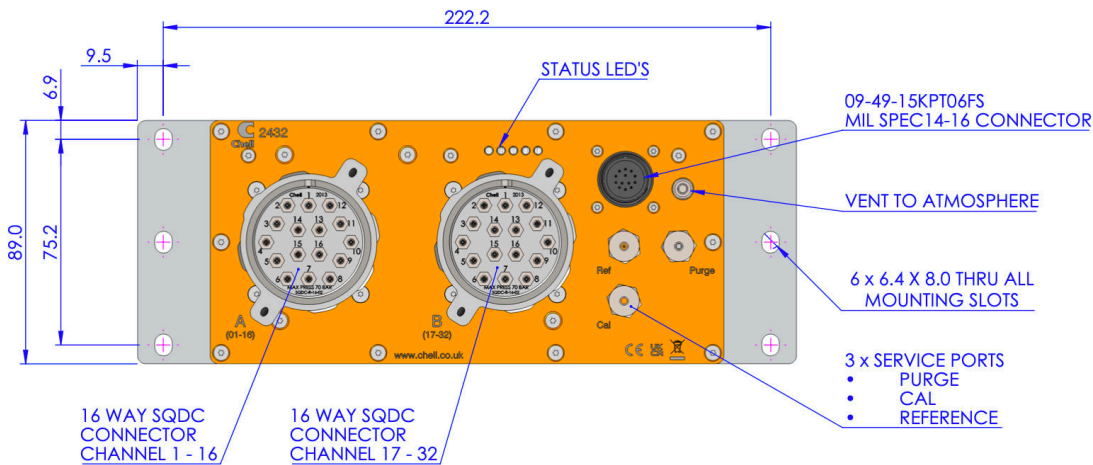

Part Number:

2432 -AABBCCDDEE

AA = Range

- 01 = 1 kPa (4" water)
- 02 = 2.5 kPa (10" water)
- 03 = 5 kPa (20" water)
- 04 = 7 kPa (1 psi)
- 05 = 10 kPa (1.5 psi)
- 06 = 17 kPa (2.5 psi)
- 07 = 35 kPa (5 psi)
- 08 = 55 kPa (8 psi)
- 09 = 103 kPa (15 psi)
- 10 = 207 kPa (30 psi)
- 11 = 310 kPa (43. psi)
- 12 = 689 kPa (100 psi)
- 13 = 1034 kPa (150 psi)

BB = Measurement Ports

- 00 = No mating Connector (blanks only)
- 01 = AQDC 1.0mm (0.040") bulged tubulations
- 02 = AQDC 1.6mm (0.063") bulged tubulations
- 03 = AQDC 1.0mm compression fittings
- 04 = AQDC 1/16" compression fittings (with Gyrolok® ferrule pairs)
- 05 = SQDC 1.0mm (0.040") bulged tubulations
- 06 = SQDC 1.6mm (0.063") bulged tubulations
- 07 = SQDC 1.0mm compression fittings
- 08 = SQDC 1/16" compression fittings (with Gyrolok® ferrule pairs)

EE = Interface Types

- 01 = Chell Interface, IENA and NetScanner emulation
- 02 = Chell Interface, IENA, NetScanner emulation and DDS
- 03 = Chell Interface, IENA, NetScanner emulation and DDS (including iDDS run time license).

DD = Service ports

- 01 = 5/16" - SAE O-ring boss
- 02 = 1/8" double ferrule compression fittings
- 03 = AS205 quick disconnect

CC = Interface / Supply

- 01 = 09-49-15KPT06FS
- 02 = TV06ZN-11-35PN-UWBSB2